

LOC	DIST	REVISIONS					
		P	LTB	DESCRIPTION	DATE	DWN	APVD
HM	00	J		REV ECO-08-027232	05NOV2008	LH	SH
		K		REV ECO-09-001027	20APR2009	LH	SH

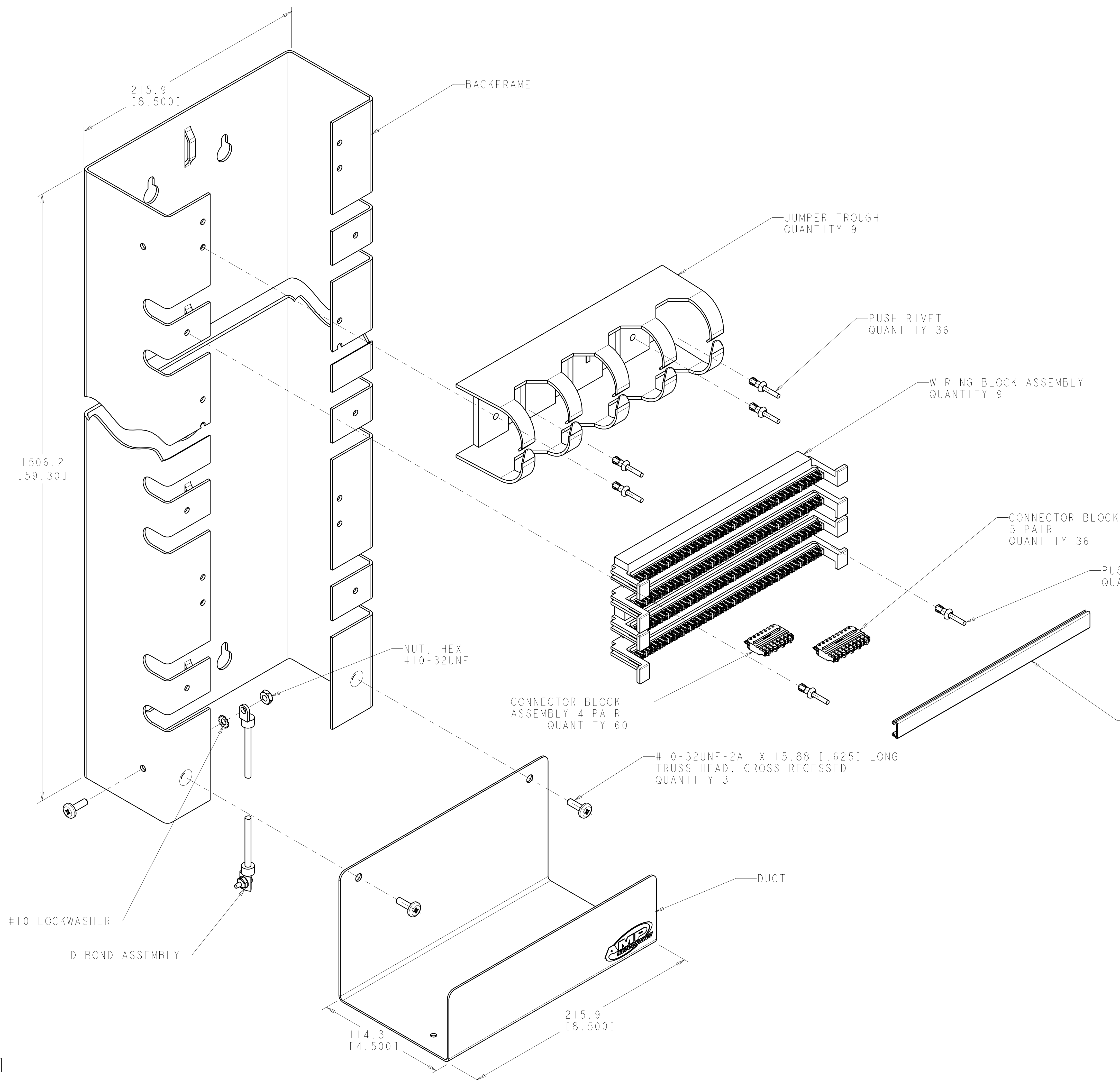

- △ MATERIAL:  
 BACKFRAME AND DUCT - CARBON STEEL, LIGHT BEIGE.  
 JUMPER TROUGH AND WIRING BLOCK ASSEMBLY -  
 POLYCARBONATE MOLDING COMPOUND, IVORY.  
 CONNECTOR BLOCK ASSEMBLY:  
 HOUSING- POLYCARBONATE MOLDING COMPOUND, IVORY.  
 TERMINALS- PHOSPHOE BRONZE PLATED WITH 3.8µm  
 [.000150] MINIMUM THICK MATTE-TIN OVER 1.27µm  
 [.000050] MINIMUM THICK NICKEL UNDERPLATE.  
 DESIGNATION STRIP - CLEAR PVC.
2. KIT SHIPPED NOT ASSEMBLED.
- △ DIMENSIONS ARE NOMINAL UNLESS OTHERWISE SPECIFIED.
4. LACING STRIPS MARKED BLACK EVERY FIFTH PAIR.

569857-1  
 PART NO.

<small>THIS DRAWING IS UNPUBLISHED. RELEASED FOR PUBLICATION BY TYCO ELECTRONICS CORPORATION. ALL RIGHTS RESERVED.</small>		DWN: T. PITTS 04APR2003 CHK: L. SMITH 04APR03 APVD: S. HERNDON 04APR03	Tyco Electronics Harrisburg, PA 17105-3608
DIMENSIONS: MM [INCHES]	TOLERANCES UNLESS OTHERWISE SPECIFIED: 9 PLC ± 1 PLC ± 2 PLC ± 3 PLC ± 4 PLC ± ANGLES ±	NAME: FRAME KIT, 110CONNECT XC, 900 PR, 4 & 5 PR CONN BLOCKS PRODUCT SPEC: APPLICATION SPEC:	SIZE: A1 CAGE CODE: 00779 DRAWING NO: C-569857 RESTRICTED TO:
MATERIAL: △	FINISH: △	WEIGHT: -	CUSTOMER DRAWING
SCALE: 1:1		SHEET 1 OF 1 REV K	